

SPECIFICATION CONTROL DRAWING

THIS DRAWING CONTAINS INFORMATION PROPRIETARY TO RF INDUSTRIES, LTD. ANY UNAUTHORIZED USE OF THIS DRAWING IS EXPRESSLY PROHIBITED. ANY VIOLATION IS PUNISHABLE UNDER U.S. COPYRIGHT LAWS.

REV	DESCRIPTION	DWN	DATE	APPROVED
B	NO CHANGES / SEPARATE BODY ITEM # 1	CZS	2/2/98	R. RICE
C	CHANGE HEX NUT THICKNESS	CZS	11/9/98	R. RICE
D	CONTACT NOW PHOS BRONZE	CZS	9/13/99	R. RICE
E	CHANGE MOUNTING CONFIG DIM	CZS	12/22/99	J. D. McR

ALL DIMENSIONS ARE REFERENCE ONLY

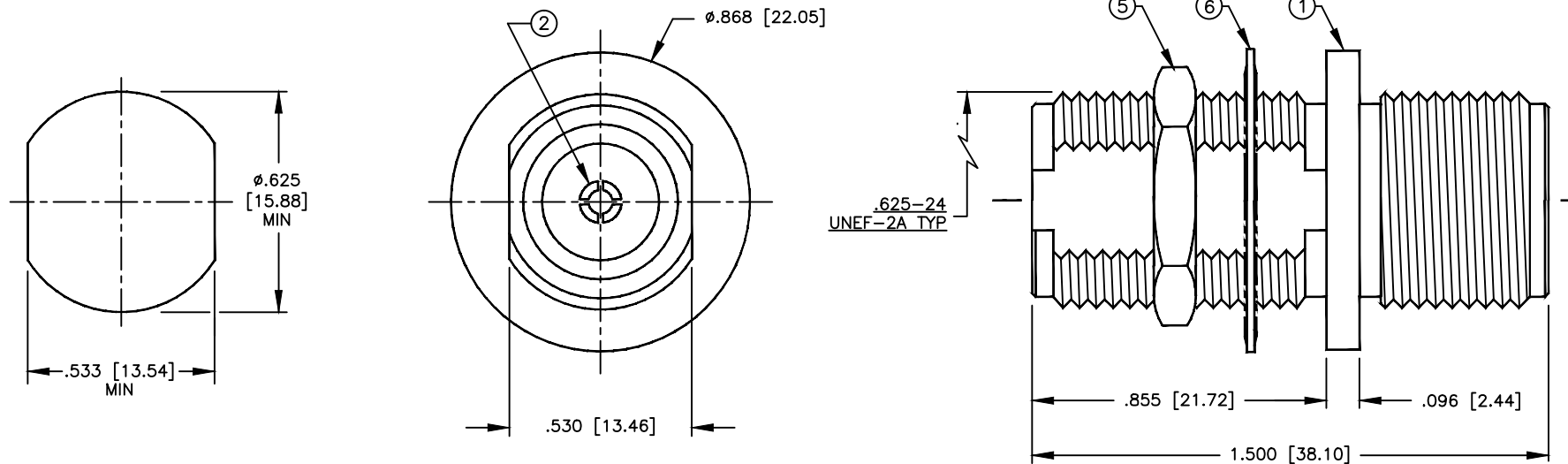

SPECIFICATIONS:

IMPEDANCE: 50 OHMS
 WORKING VOLTAGE: 1000 VRMS @ SEA LEVEL
 FREQUENCY RANGE: 0-11 GHz
 INTERFACE PER MIL-STD-348, SECTION 304.2

DIMENSIONS ARE IN INCHES AND [MILLIMETERS]

UNLESS OTHERWISE NOTED TOLERANCES ARE:
 DECIMALS DIAMETER

RFconnectors
 DIVISION OF RF INDUSTRIES, LTD.

7610 MIRAMAR RD
 SAN DIEGO, CA 92126
 (858) 549-6340
 (858) 549-6345 FAX

RFN-1023 / UG-30C/U
 N FEMALE TO N FEMALE BULKHEAD
 FRONT MOUNT ADAPTER

ITEM	DESCRIPTION	QTY	MATERIAL	FINISH
6	LOCK WASHER (LKW-625)	1	BRASS	SILVER
5	HEX NUT (HEX-625-24E)	1	BRASS	SILVER
4	PRESS-FIT GROUND RING	1	BRASS	SILVER
3	DIELECTRIC	2	PTFE	NONE
2	CONTACT	1	PHOS BRONZE	SILVER
1	BODY	1	BRASS	SILVER

DRAWN C. ZUNIGA	12/22/99
CHECKED	
ORJ DRAWN K. MAXWELL	1/11/94
APPROVALS	DATE

SIZE A	CABLE GROUP N/A	DWG NO. 8283	REV E
SCALE: 2:1		CAD FILE 13ARC B	SHEET 1 OF 1